



THE
PDMA TOOLBOOK
for New Product Development

Edited by

ABBIE GRIFFIN

STEPHEN M. SOMERMEYER

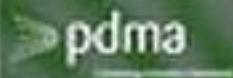

PRODUCT DEVELOPMENT &
MANAGEMENT ASSOCIATION

TRIZ: The Theory of Inventive Problem Solving
Gunter Ladewig
President
PRIMA Performance Ltd.

BREAKTHROUGH PRODUCTS AND PROCESSES WITH 7 INVENTIVE TECHNIQUES

Genrich Saulovich Altshuller (1926 – 1998), wondered, “Could inventions be the result of systematic inventive thinking?” Over half a century, Altshuller and his associates investigated some 200,000 patents. Their work resulted in the breakthrough discovery that of ninety-five percent of all patents used only seven inventive tools. Only five percent come from breakthroughs in science and brand new ideas (See References, Savransky, D. Semyon). They found that exceptional patents improved performance by resolving contradictory requirements, like increasing speed without higher fuel consumption. Another revelation was the frequent occurrence of a windfall of benefits, or super-effects, which arose from resolving a system’s fundamental contradiction. Not only were many costly add-ons and expensive tolerances no longer required, many systems had inherited valuable, new, product differentiating, capabilities and features. Altshuller also found that if patents were categorized by what they did functionally, rather than by industry, the same problem had been solved over and over again with just a handful of inventive techniques. The result, TRIZ, a Russian acronym for The Theory of Inventive Problem Solving, provides us with a methodology for engineered creativity.

TRIZ is a methodology that provides product and process designers with inventive problem solving tools that not only accelerate the design process but help them achieve world class performance improvements beyond the trade-offs most designers consider unavoidable. Because TRIZ uses a functional approach to problem solving, it is equally applicable to solving business dilemmas faced by a giant steel mill as it is for micro-chips or potato chips. It reaches across many different functional lines, not just product development.

TRIZ can provide the marketing team with inventive techniques for product renaissance, both through product differentiation and competitive analyses. They can ‘Jazz-up’ their products with brand new applications, or they can put ‘wings’ on their product or process with desirable new features.

Finally, TRIZ is an inventive problem solving tool that can be used by the continuous improvement team in charge of Value Analysis/Value Engineering (VA/VE), ‘Lean’ or ‘Six sigma’ initiatives. In a most uncompromising way, TRIZ can be used to ‘cut off’, i.e. eliminate costly and poor quality components and then make the pruned system work again through applying several inventive techniques. Saying it another way, TRIZ defines the problem and then walks around it with inventive techniques to find a solution. The following pages illustrate the use of seven inventive TRIZ techniques, first conceptually and then again by using a real product example, a vacuum cleaner.

But first, a few words about creativity activation. In facing a problem solution space, most of our knowledge is confined to our industry, background, and education. We can start

fresh each time by using Trial & Error, Brainstorming, or other creativity unleashing methods like Synectics, to generate 'Out of the Box' solutions. But there are other choices. Should we try to get as many ideas as possible (brainstorming), or should we try to get quality ideas? What's more important: head count, i.e. many 'brainstormers' in one room, or head content? Should we emulate the traits of great inventors or should we use their tools? Our choice is to get the best ideas from the best inventors by using their best tools, TRIZ, a methodology, derived from empirical data, not theory, of the real world, the world-wide patent base. TRIZ provides a systematic approach for idea generation, speeds up creative thinking, and significantly expands the range of problem solving options.

This chapter first introduces TRIZ as a general methodology, and then sets up the example that will be used to illustrate the inventive techniques. Then each of seven inventive techniques is explained in detail, and applied to the example. Finally, the chapter closes with keys to success and pitfalls to avoid when using these techniques.

TRIZ Flow Chart: The following problem solving flow chart (see Figure 1) provides roadmaps for different system problems. Column 1 provides the roadmap for system performance improvement through contradiction or trade-off elimination. Column 2 is used to determine a product's evolutionary maturity (remaining 'head room' for improvement and benchmarking). Column 3 is used for product differentiation by providing the existing product with brand new applications and/or unique features. In addition, it can also be used as a competitive analysis benchmarking tool. Column 4 is a rather specialized tool used for the improvement of measurement systems.

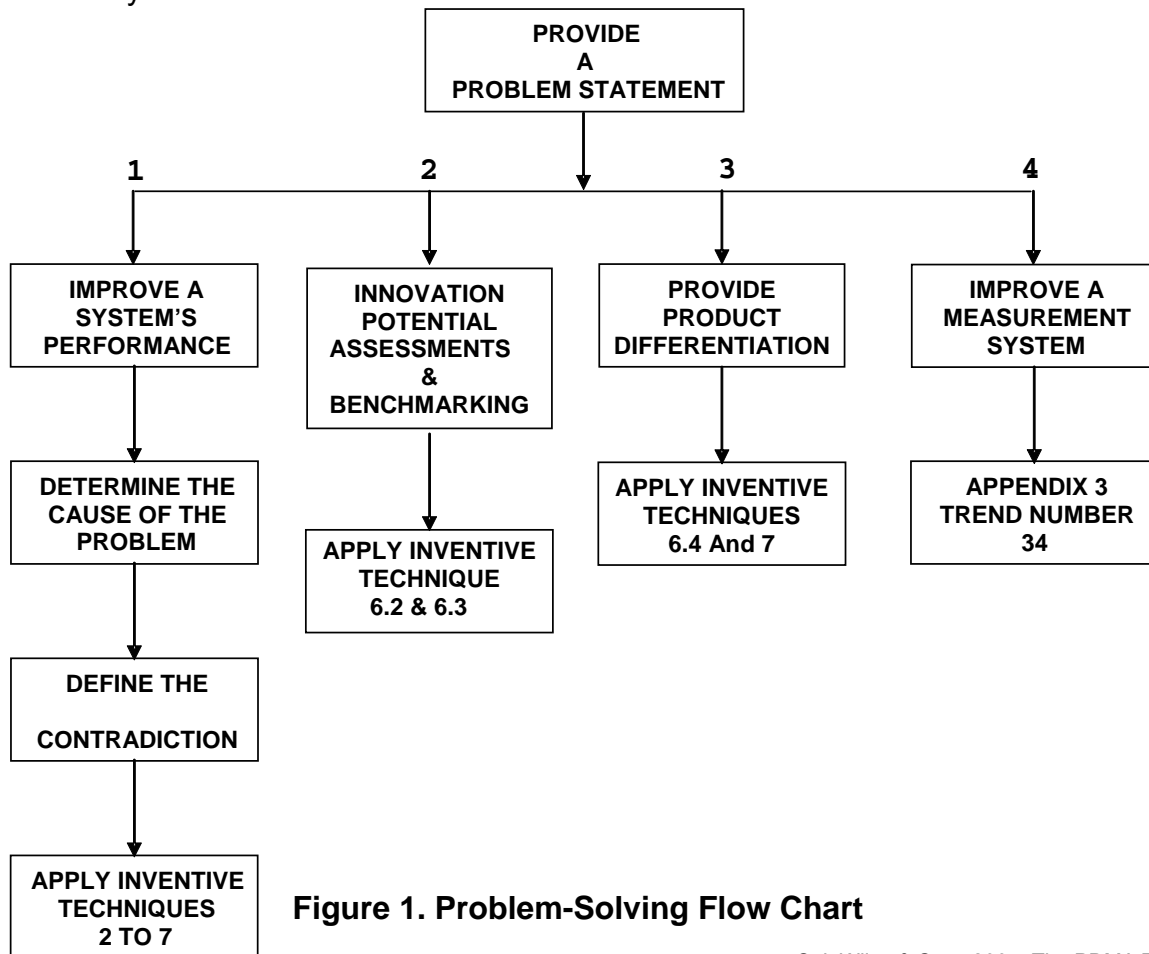

Figure 1. Problem-Solving Flow Chart

General Problem Statement: Improve the efficiency and reduce the cost of power brush vacuum cleaners using seven different techniques. Each technique will be illustrated, first with generalized conceptual examples, and then by applying them to the vacuum cleaner. Even though these techniques are different, they all strive to eliminate the linkage of contradictory requirements using one common approach namely, separation. For this reason, solutions from different techniques will in some cases be the same or have overlapping features. Vacuum cleaners considered include central vacuum cleaners, floor models, and uprights. Vacuum cleaners remove dirt, dust and debris from floors, carpets and other surfaces by supplying both high suction force to lift or free trapped debris from a carpet and also high air flow to transport the debris away quickly and enable rapid cleaning. Please note that ways to obtain self-cleaning carpets are not being sought, although this could be another goal for TRIZ. In this case, the problem under investigation is to improve the vacuum cleaner's efficiency.

The first step in applying TRIZ is to find the cause¹ that is constraining the system's main function, i.e. action. An analysis of the vacuum cleaner reveals that its main function (action), providing suction force, i.e. 'pull debris', is severely limited by atmospheric pressure, which is an absolute maximum of 14.7 pounds per square inch (PSI). In fact, most vacuum cleaners rarely generate 3 PSI of suction. To overcome this constraint, many vacuum cleaner manufactures add a costly, electric motor driven power brush (see Figure 2) that provide additional force for separating dirt from the surface being cleaned.



Figure 2. Electric power brush

TECHNIQUE 1: FORMULATE THE CONTRADICTION: (conceptual example)

A contradiction occurs when an improvement in one part of a product or system fundamentally causes deterioration in another part. Our fundamental premise is that all improvements are sub-optimal unless the fundamental contradiction, or tug-of-war, causing the problem is unearthed and eliminated without tradeoff in performance of any other aspect of the system. The goal is to somehow separate these opposing requirements so they can't exert a detrimental influence on one another.

To formulate the contradiction:

Step 1: State the primary function of the system.

Step 2: Transform the problem into a contradiction statement by defining what it is that is reducing the primary function's effectiveness.

As one example, consider the goals of a manufacturing facility. At a particular time, the primary goal of a manufacturing plant might be to increase throughput. The contradiction then becomes how to provide maximum throughput, while minimizing inventory cost:

For high throughput \uparrow : Increase \uparrow parts supply, but then there are excessive inventory costs.
For low throughput \downarrow : Reduce \downarrow parts supply, and then inventory costs are minimized.

From the above we see that parts supply is the issue. The goal, to have both high throughput and low inventory cost, is obtained with a Just in Time, JIT, manufacturing strategy. The contradiction of having parts and not having parts was solved by separating the two opposing requirements in time: provide parts only when needed so that inventory cost is minimized.

Step 3: To help solve a contradiction, intensify it by stating the extremes of the conflict. Stating extremes clarifies the contradiction and thus gets us out of the 'box' of current of thinking. For example, a picture that is very small, non-existent, and simultaneously very large, infinite. Answer, a picture in the computer's memory is very small and can't be seen, yet when displayed on the monitor it is very 'large' and can be seen by someone with a notebook computer on the moon.

Step 4: To better visualize the contradiction and energize creative problem solving, draw a picture of the conflict zone.

Step 5: Map primary and harmful function's time durations if a temporal relationship exists.

The Vacuum Cleaner's Contradiction

There are two different strategies or levels of solution that can be used to improve the vacuum cleaner:

- Strategy 1 would be to eliminate the problem cause, i.e. the vacuum cleaner's inherent (Without power brush) design contradiction. (See Figure 3, the 'optimized', vacuum motor fan assembly trade-off)
- Strategy 2 would strive to eliminate the contradiction arising from the need of a costly power brush add-on to obtain superior cleaning. This is referred to in TRIZ as a paired object contradiction, i.e. the bare 'bones' vacuum cleaner (poor cleaning) versus one with power brush add-on (costly).

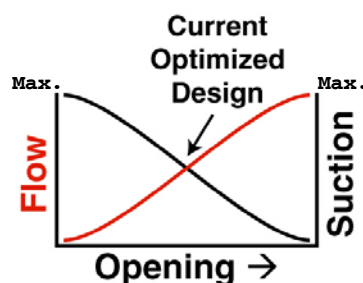

Figure 3. Trade-off performance design chart

Although not totally accurate, Techniques 1, 4, 5, and 6 employ strategy 1, while techniques 2, 3, and 7 generally employ strategy 2.

A different project might have decided to improve the vacuum's performance by eliminating problems associated with clogging of the filter. If the filter was selected, the project would start by defining its primary function and then its contradiction. The filter issue will be revisited at the end of technique 3.

General Problem Statement: This project's goal is to improve the poor cleaning capability of the vacuum cleaner so we can eliminate the expensive electric power brush add-on. The first step is to define the vacuum cleaner's primary function.

Step 1: The Vacuum's primary function: To clean (remove or pull debris from the carpet)

Step 2: Contradiction: How to provide both maximum suction and flow. (See Figure 3, the 'Optimized', trade-off performance design chart below)

For good cleaning↑: high suction↑ is required, but then air flow is reduced↓
For poor cleaning↓: low suction↓ can be used, but then air flow increases↑

Step 3: State the intensified extremes of the conflict, if the vacuum is close to the carpet, i.e. stuck to it, we have maximum suction, but we have zero flow, and no debris removal. If the vacuum is far from the carpet, we have little suction to remove debris, but we have maximum air flow, and again, little or no debris removal. The formulated intensified contradiction becomes:

For maximum cleaning↑↑: maximum force↑↑ is needed, but then there is zero flow↓↓.
For minimum cleaning↓↓: minimum force↓↓ is needed, but then there is high flow↑↑.

The contradiction to be solved is therefore: A vacuum cleaner with both maximum suction and maximum air flow is the answer!

Several points about solving contradictions are in order. First, there are two approaches possible for solving each contradiction: one approach involves improving the first attribute, the suction force of the vacuum cleaner, and one involves improving the second attribute, the flow of the vacuum cleaner. For most situations the approach that most closely represents the main function, in this case cleaning using maximum suction or pulling force, is chosen for the improvement path.

However, if the conflict is intensified, two more options arise. If after intensification, it becomes impossible to execute the main function, nozzle stuck to the carpet and no flow, then the other approach to resolving the conflict should be taken. This does not mean the overall goal is compromised. The contradiction still must be solved and both of the conflicting attributes maximized. On the other hand, if intensification destroys the product or object the primary function is acting on (in this case, debris), select the conflict that most closely represents the main function, but then try to solve a modified version by slightly backing off from the extreme state of intensification.

Please note that if a satisfactory solution to the problem is not obtained after applying all seven techniques, select the opposite version of the conflict and repeat the problem solving process.

Step 4: Draw the conflict zone domain (See Figure 4).

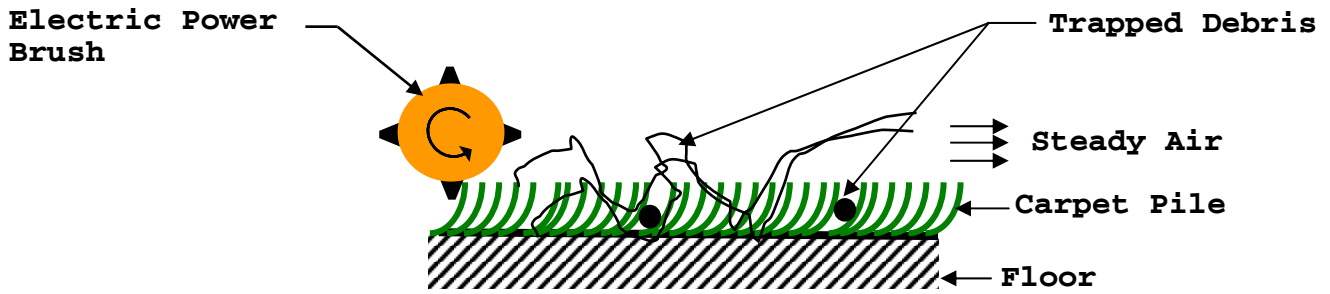

Figure 4. Conflict Zone Domain

Step 5: Draw the pre, post, and during conflict time domain. The time domain of primary and harmful functions indicate steady state air suction or pulling force, and an intermittent pulling force exerted by the rotating electric power brush. (See Figure 5)

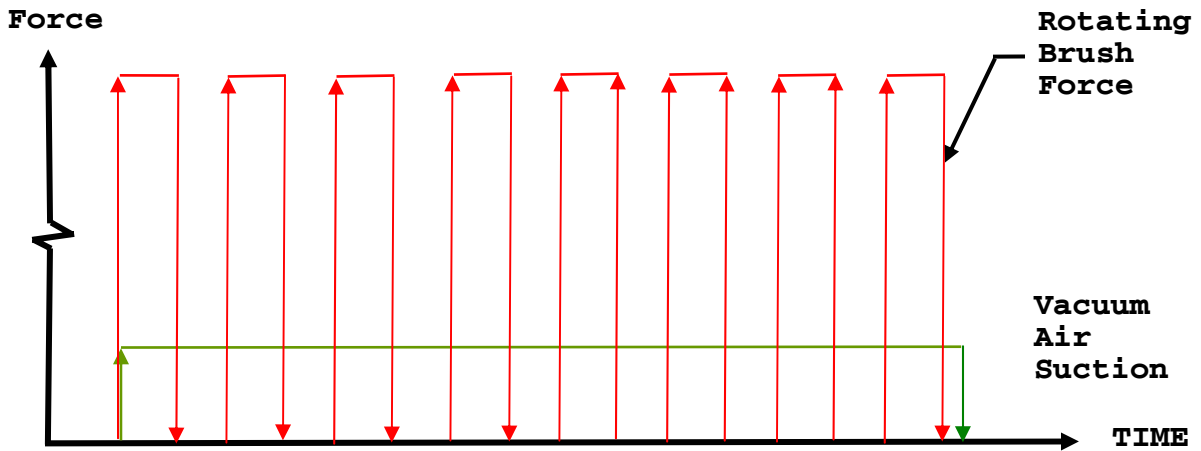

Figure 5. Force Time Domain

Frequently, just by intensifying the contradiction, drawing pictures of the conflict zone domain, and mapping the time domain, solutions come to mind and the problem is solved. The above may suggest to somehow provide oscillating, high/low air pressure pulses, instead of the power brush, to wiggle and dislodge trapped debris for improved cleaning. If a solution is not obtained at this stage, proceed to the following techniques which provide different tools for solving contradictions.

PROCESS QUICK CHECK: If the contradiction is experienced by a single object, e.g. air requiring both high suction force (no flow) and high flow (little suction), skip to Technique 4, Physical Separation Techniques. This is an example of contradiction solving strategy 1. If strategy 2, (paired object contradiction) elimination of the expensive power brush add-on is desired, proceed to the next step.

TECHNIQUE 2: FORMULATE THE IDEAL FINAL RESULT AND DEFINE THE IDEAL MACHINE:

The ideal final result (IFR) is a technique that removes us from the psychological inertia of the current way of thinking or doing things. What is important is that IFR frees us from the physical ways of achieving our goal by defining the desired resulting end state. Saying it another way, we work back from the answer, or desired function. An example of an ideal final result would be: give me the hole, not the drill. This approach provides us with new alternatives to achieve our goal, and sometimes, all on its own, provides us with breakthrough solutions already at this stage of the TRIZ problem solving process.

The ideal machine is a machine that performs its function but does not exist. We can create the ideal machine simply by transferring the function from machine 1 to another machine, i.e. machine 2. We thereby eliminate machine 1. Machine 1 has become the ideal machine; it performs its function but does not exist (we get it for free). One example of an ideal machine would be the carpenter's hammer. It is both a hammer and a crow bar. The crow bar's function has been transferred to the hammer. The crow bar doesn't exist, yet the hammer performs its function. It has become the ideal machine.

The ideal final result and the ideal machine concepts can be used together to eliminate a contradiction. The hub cap on an automobile's wheel introduces the contradiction of providing a pleasing appearance, its primary function, but at a negative function of increased probability that it comes off. The ideal final result desired from the hub cap is improved secure adhesion. By transferring the hub cap's aesthetics function to the wheel's rim, designing and manufacturing a rim with a pleasing appearance, (and not using the hub cap) creates an ideal machine. The primary function of aesthetics is retained, but since the hub cap no longer exists, the negative function of losing it has been eliminated. The contradiction is solved.

In the same way, Value Engineering, Lean Manufacturing or Six Sigma 'aficionados' can use the IFR and ideal machine concepts to transfer to another resource the desirable functions and thus 'prune' costly or defect prone components from the system. Hence, many expensive and time consuming improvement techniques, like design of experiments, do not always have to be used to solve every problem. The cause of the problem can be identified and dealt with either by using already existing resources to perform corrective actions or by 'pruning' it away altogether. The cause of the problem was simply identified, and then walked around by using the ideal machine concept.¹

The Vacuum Cleaner's Ideal Final Result and Ideal Machine:

The desired ideal final result or function is: 'Give me the high force of the power brush' (without the power brush). The question then becomes whether there is there any resource, component or force, in the vacuum cleaner or its environment that can be used to provide this IFR? Is there anything in the existing system or its environment that can provide high force (ideal result) and at the same time eliminate the costly power brush (ideal machine)? One solution is

¹ Please note, in general terms TRIZ defines a resource as any substance (component), or field (force and energy) of the problem entity or its environment. Space, time, information and functions are also considered resources.

obtained by using the pushing power of the operator to rotate the roller brush and thus eliminate, at a minimum, the power brush motor. Other potential alternatives that come to mind are the use of electro-statically dust repellant carpets, or the use of electro-static energy generated by the air flow to assist suction in removing debris. These alternatives will be investigated further as other inventive techniques are applied to the problem

TECHNIQUE 3: SOLVE THE PROBLEM USING FUNCTIONAL DIAGRAMS AND 'PRUNING'

TRIZ provides several systematic methodologies that assist in improving the performance of technological systems. The first of these is the use of functional diagrams and 'pruning'.

This TRIZ procedure applies the principles of value analysis, developed by Lawrence Miles, to costly, poor quality, or inefficient trade-off-causing components by simply cutting them off or pruning them. This technique shows how to obtain the Ideal Final Result and Ideal Machine for 'free'. However, before constructing the vacuum cleaner's Functional Diagram, a few points about technological systems, functions and the method for constructing a function diagram are in order.

A technological system consists of a set of objects or subsystems that perform a set of specific functions on a product. Generally speaking, a technological system consists of a working tool, which provides the primary function, an engine that provides energy, a transmission for carrying the energy, control for managing energy flow, the casing that maintains its structure, and provides safety and aesthetics, and finally the super-system, i.e. the larger system the itself is part of. The vacuum cleaner is one example of a technological system whose primary function, "cleaning," is performed by a tool (double lined box), "air," that exerts a force, "pull," on a product (dotted lined box), "debris." This air-pulls-debris example represents the most basic unit or model of a technological system and is referred to in TRIZ as a Substance-Field, S-F unit (See Figure 6).



Figure 6. Substance-Field Function Diagram

The tool and product may also represent two systems, or two substances, or two components, or a system exerting a force on a single component or product. Larger, more complex technological systems like the remaining parts of the vacuum cleaner can be modeled by linking many individual S-F units. Fields may represent any force that's mechanical, thermal, chemical, electrical, magnetic, or electro-magnetic. Each field in turn can be represented by many sub-categories. For example, a mechanical field may be surface tension, friction, centrifugal force, inertia, pressure gravity, etc. There are three types of fields: the primary field (the one that is in conflict), support fields, and harmful (or costly) fields. Each field in turn may be scaled for its effectiveness as insufficient or excessive (uncontrolled). Finally, an **X** indicates a component that's unwanted and should be pruned off (See Figure 7 for field or arrow conventions).

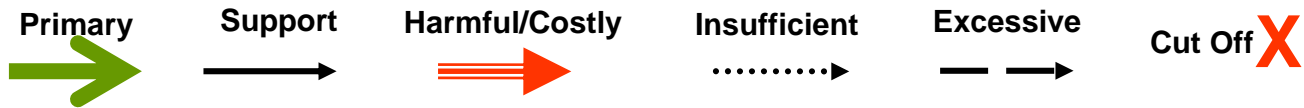

Figure 7. Functions

To construct a function diagram:

1. List all system components to obtain many potential choices for finding the Ideal Machine to which the desirable functions can be transferred while leaving behind undesirable ones to be pruned off.
2. Start the function diagram by connecting the tool with an arrow, which represents the primary field, to the product.
3. Connect other components near the conflict zone to the tool-to-product S-F model, making sure that all components causing the conflict are included.
4. Label all other fields as useful, or harmful.
5. Next scale all fields for their effectiveness. Please refer to the arrow conventions in Figure 6.
6. Scaling helps focus our efforts on what has to be improved, controlled, or pruned.
7. Use simple words and phrases for functional field descriptions. Simple phrases instead of restrictive professional jargon provide us with more choices for obtaining the Ideal Final Result, or function.
8. Minimize the size of the function diagram by not expanding to far beyond the conflict zone.
9. It is important to make sure that all desirable support functions are included so that they are not unknowingly cut off when the harmful, costly, poor quality, or low performance functions are pruned.
10. Prune off components that cause the conflict or other harmful problems, and transfer their desirable functions to other remaining components, i.e. to the Ideal Machine.
11. If issues arise because satisfactory components or fields can't be found for transfer, (or for intervention to compensate for insufficient/excessive actions):
 - Review other components listed in step 1 for possible inclusion in the function diagram, or
 - See Appendix 4, Ideal ways of eliminating a harmful action, or
 - See Appendix 5, Inserting a substance or field, and Appendix 6 Fields from science, or
 - Review the Effect Data Base, Technique 7, for possible solutions.

A general example: A laboratory studies small disks of material specimens by placing them into a crucible, immersing them in aggressive solutions and subsequently analyzing the solution. Unfortunately, some aggressive solutions not only attack the specimen but also the crucible, which in turn causes a contaminated solution and erroneous results. Figure 8 shows the function diagram and the solution's harmful action on the crucible.



Figure 8. Function diagram with harmful action

Both the specimen and the aggressive solution must be retained. The crucible indirectly causes contamination. The crucible can be ‘pruned’ and its hold solution function, (IFR), transferred to the specimen disk. This can be accomplished by creating a small depression in the specimen disk’s top surface to hold a few drops of solution. The specimen disk has become the Ideal Machine or crucible, one that performs the crucible’s holding function, but without existing (Figure 9).

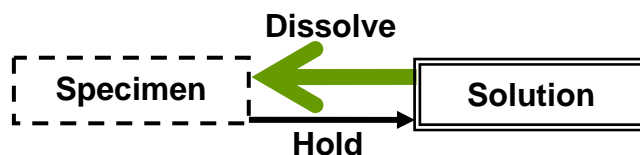

Figure 9. ‘Pruned’ function diagram

Use Functional Diagrams and Pruning to solve for the vacuum cleaner:

First we must reformulate the contradiction because our goal in this case is the elimination of the electric power brush, i.e. strategy 2, as mentioned earlier in Technique1.

1 – State the vacuum cleaner’s primary function: Cleaning or PULL debris from the carpet.

2 – State the contradiction:

- For improved pull↑: The power brush is required ↑, but then savings are reduced↓.
- For reduced pull↓: A small power brush required ↓, and then savings improve ↑.

3 – State the intensified contradiction:

- For maximum pull↑↑: A very powerful brush is required↑↑, but then the carpet is damaged↓↓.
- For very little pull↓↓: No power brush is required↓↓, then savings are maximized↑↑.

Since after intensifying the contradiction (see Technique 1), it is impossible to execute the main function, i.e. the carpet is damaged, solve the opposite version of the conflict (little pull).

NOTE: This does not mean we abandon our goal of superior cleaning. The goal remains maximum cleaning without a power brush.

Start by drawing the primary function Substance-Field diagram by connecting the tool, air, with the primary field, pulls, to the object or product, the debris to be removed (Figure 10). Since the primary function is insufficient to solve the contradiction, it is scaled with a dotted arrow. (See Figure 7 for arrow conventions.) Connect with fields (arrows) other nearby components like the vacuum motor, fan, filter, brush motor, and the operator (super-system, not shown) to the previously described primary function Substance-Field diagram. Because the brush motor and the brush are not wanted due to their high cost, they are marked with an X for pruning. Since the dust filter resists air flow, especially once it gets clogged with debris it is added to the diagram and shown as having a harmful, uncontrolled (dashed line) function that resists air flow. In addition, since the dust filter's support functions of holding debris and cleaning air aren't 100% effective, they are scaled with dotted arrows as insufficient.

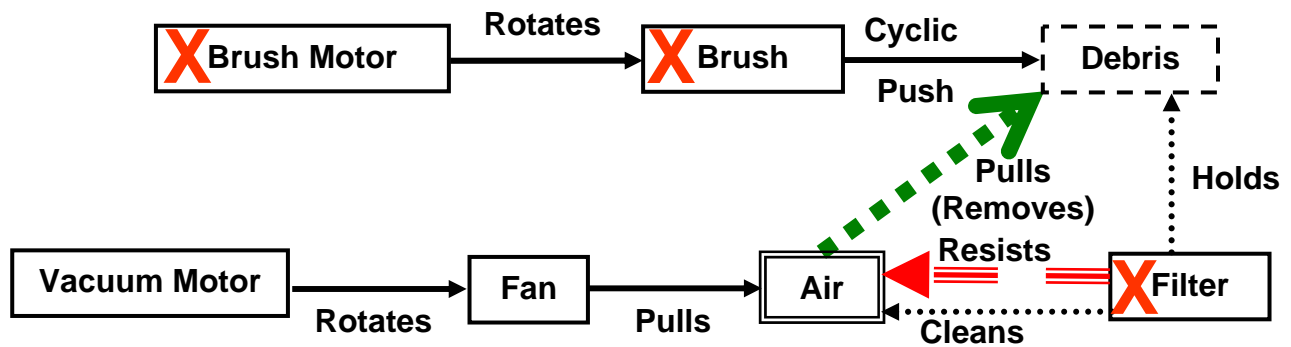

Figure 10. Vacuum cleaner function diagram

The first objective is to cut off (prune) the brush motor and brush assembly and assign their functions to something else, without adding anything new to the system. Some other component must provide cyclical pushing of debris. But what? Perhaps the fan can provide not only suction flow, but in addition, provide high pressure, pulsed jets of low flow air from its exhaust port (or possibly a second fan impeller).

Next, for even greater performance, the filter may be pruned as well. But with the filter removed, the air is filled with debris, creating another contradiction. 'Dirty' air that removes debris is needed and 'clean' air that doesn't spew debris everywhere also is needed. Can these conflicting requirements now be solved simultaneously? Yes, with cyclonic, self-cleaning air that removes debris particles with centrifugal force. This in fact is the principle used by the Dyson Cyclone vacuum cleaner.

To finish, the new pruned system is reconnected and verified for proper operation. The fan inherits a new air pushing force from its exhaust port. The air gets another primary cleaning function, pulsed push, and also a new support function, cyclonic self-cleaning. Since the vacuum cleaner's debris removal performance (Pulls), and air's cleaning function (cyclonic self-cleaning) are both much improved, dotted arrows (insufficient) are replaced with solid arrows.

*One final comment regarding the air filter problem above. The Invention Matrix, to be discussed in technique 5, could have been used as well to provide the same answer. If debris removal is improved using a filter, attribute 26: Quantity of Substance then attributes 22: Energy, reduce air flow deteriorates. At the column/row intersection resides Inventive Principle, 22, Self-service, i.e. self-cleaning air. Please refer to Figure 11, for the pruned and reconnected function diagram of the vacuum cleaner. (Note: If we were really stuck for a solution, use of the Physical Effects software² database, discussed in technique 7, might provide answers. By entering search words like filter, the data base would suggest numerous alternatives including the use of centrifugal force.)

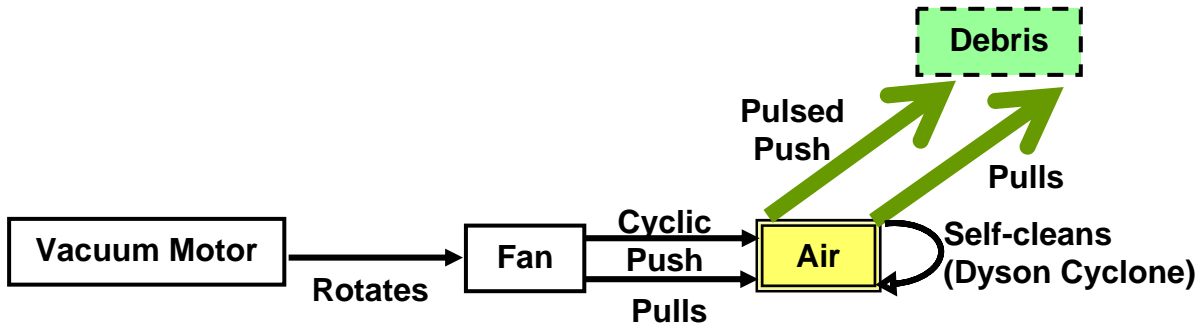

Figure 11. 'Pruned' and reconnected vacuum cleaner function diagram

TECHNIQUE 4: SOLVE USING 'PHYSICAL SEPARATION' TECHNIQUES

These TRIZ techniques are used when the contradiction is experienced by a single object as opposed to a pair of objects or sub-systems 'fighting' one another. For example, tongs are needed that can become hot at one end that is moving food around a grill and yet remain cold at the other end where they are held. As another example, glasses are desired that transmit and retard light transmission, subject to the light's intensity. In low light, they transmit, while at higher light intensities, they partially block transmission. There are four ways to separate mutually exclusive requirements acting on a single object:

Space: Separate conflicting requirements acting on a single object by putting distance between the requirements. As mentioned above, tongs must be hot for holding hot objects and they must be cold so that the hand holding them will not burn. This contradiction may be solved by allowing sufficient distance between the hand and the end of the tong holding the hot object. Another example of separation in space would be the bifocal lens in glasses, where the top part of the lens helps wearers focus on objects in the distance, while the bottom part of the lens provides focus for close-up situations such as reading.

Time: Separate conflicting requirements with time. The airplane wing has to be large for maximum lift at takeoff and it must be small for minimum drag when at high speed. These mutually exclusive requirements of large versus small can be separated by adjusting the wing's size from initially large to small later on by having retractable flaps or extensions. Another example would be Just in Time inventory management. By

managing the delivery time of inventory, there is no inventory when it is not needed and simultaneously, inventory right when it is needed.

Condition: Separate based on the situation encountered. An example might be the requirement for an object to attract and not to attract iron. One way to provide both holding and release capability is with the use of an electromagnet. When turned on, it attracts iron. When off, however, there is no attraction. The self-adjusting glasses that change their opaqueness subject to the light intensity are another example.

Whole vs. Portion: The whole entity has one characteristic, and portions of the whole have other characteristics. One example is the strainer; the whole strainer retains the spaghetti, yet individual holes allow for separation of the water from the pasta. Another example is the bicycle chain. Individual links are rigid, yet the 'whole' chain is flexible.

Using Physical Separation to solve the vacuum cleaner problem:

The vacuum cleaner requires high suction (no flow), and high flow (no suction). Since a single entity, the air, experiences both requirements, physical separation techniques can be used to solve this problem.

The process is to try to apply each of the four physical separation techniques – space, time, condition, or whole vs. portion – to the air in turn, to see if any of them can be used to satisfy both requirements of the conflict. The separation technique of condition does not seem to apply to solving this problem. In considering the separation principle of "Space", one way to try to solve the flow versus suction conflict is by providing areas of high flow, large openings, and areas of low flow (high suction) in the vacuum cleaner's end effector. In fact, many current designs use cut outs in portions of the bristle brush of the end effector to provide areas of high flow and other areas of high suction. The whole vs. portion separation technique also is already used in vacuum cleaner designs. The bristle brush around the vacuum head already tries to solve this contradiction by providing low flow (high pressure) with the small spaces between individual bristles and the floor. On the other hand, high flow (low pressure) aggregated flow is provided by the whole brush-to-floor interface.

The separation in time principle suggests another potential solution not yet incorporated into standard vacuum design. Both seemingly exclusive requirements can be satisfied by introducing air pulsations. Air pulsation oscillates between maximum suction (no flow) and maximum flow (no suction), using the dynamics between the two maxima to potentially clear debris more effectively.

TECHNIQUE 5: SOLVE THE CONTRADICTION BY USING THE INVENTION MATRIX

Altshuller refers to the distinguishing properties of objects, or of the subsystems that comprise a technological system, as their attributes. He discovered that, despite the immense variety of technological systems, any technological system could be completely defined with only 39 attributes, such as strength, weight, reliability, and complexity, to name a few. Frequently, improving performance in one attribute inherently comes at the detriment of performance on another attribute, creating a contradiction. Since great inventions resolve system

contradictions, any contradiction could now be defined in an 'Invention Matrix', (see Figure 12), consisting of improved attributes (Y axis) versus deteriorating attributes (X axis).

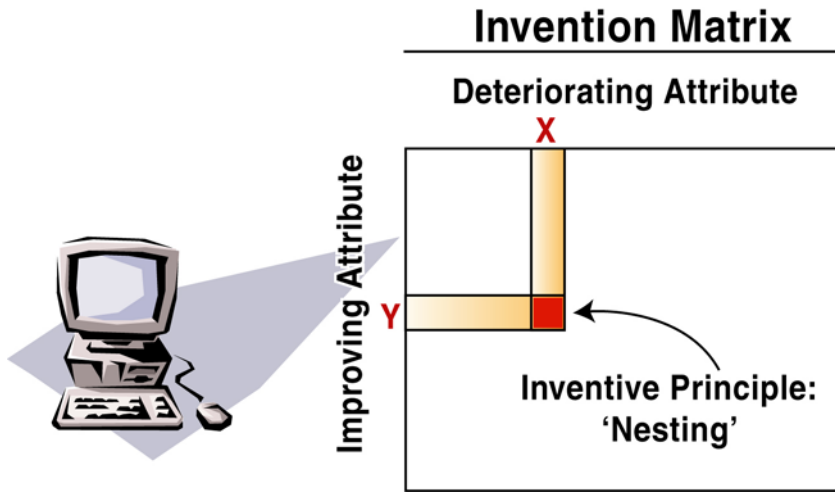

Figure 12. Invention Matrix Structure

Altshuller's actual Invention Matrix is shown in Appendix 1. Improving attributes are listed in the left column. The same 39, but worsening, attributes also are listed across the top of the matrix. After defining inherently occurring conflicts like improving strength (Y axis, attribute 14) versus increased, worsening weight (X axis, attributes 1 or 2), or improving productivity (Y axis, attribute 39) versus deteriorating precision (X axis, attribute 29), Altshuller researched the world-wide patent base for the very best solutions to these conflicting requirements across all available systems. He and his associates discovered that only 40 Inventive Principles were used over and over to resolve conflicts between these 39 attributes. Please note contradictions may be formulated for a single object (a pointer), or for contradictions between a pair of objects/sub-systems. Appendix 2 provides definitions and brief descriptions of examples for all 40 Inventive Principles.

The result is the 'Invention Matrix' of Appendix 1, which allows any system conflicts to be defined, and in addition, suggests a number of potential solutions based on the Inventive Principles. These potential solutions can be found in the intersection of the conflicting row and column attributes. For example, an increase in Productivity/Capacity, system attribute 39, located at the bottom of the left column in the matrix, might lead to worsening Manufacturing precision, number 29, located in the top row of the matrix. At the intersection of these two X-Y contradictory attributes are numbers for the Inventive Principles that have been found, from a review of the patent literature, to have resolved this conflict in previous inventions. At the cross-roads of attributes 39 and 29 are four numbers: 18, 10, 32, and 1. These four numbers represent four high potential, analogous solutions, based on the Inventive Principles, to the productivity versus precision conflict. The four Inventive Principle potential solutions suggest using:

- 1: Segmentation
- 10: Preliminary Action
- 18: Mechanical Vibrations/Oscillations:
 - a – for example, use a hammer drill, or
 - b – increase the frequency by going to ultrasonics, or
 - c – use resonance as used in the destruction of kidney stones, or
 - d – use piezoelectric vibration as used in quartz crystal watches, or
 - e – use electromagnetic energy in combination with the above vibrations, or
- 32: Changing Color or Optical Properties,

or combinations of these four principles to solve our conflict.

Although not necessary, commercial software² is available that not only helps solve the contradiction by providing Inventive Principles (solutions), but in addition, provides examples of solutions from many industries. Please see the endnotes of this chapter for details about this software.

As one example of how to use the Inventive Matrix, consider improving the performance of a pointer. First, define the contradiction for a pointer: It should be both: long (to reach the board) and short (to fit in a pocket). Then:

- Locate on the 'Y' axis, the attribute (1 to 39) to be improved: length. Select the attribute that most closely represents the desired need, in this case (3) Length of mobile object
- Locate on the 'X' axis the attribute that deteriorates when conventional means are used to obtain a long pointer, for example, it doesn't fit into the pocket, its volume increases, in this case (7) Volume of mobile object
- At the 'X – Y' intersection, the matrix suggests four Inventive Principles that may apply to how the contradiction can be resolved:
 - 7: Nesting: Place objects inside one another; paper cups, mechanical pencil
 - 17: Transition into a new dimension: Go in other directions, project optical lines
 - 4: Asymmetry: Replace symmetrical objects with asymmetrical objects or vice versa
 - 35: Transformation of properties: Change object's physical state, solid, gas, liquid, rheology, magnetorheological materials

Note: Inventive Principles are listed in order of highest probability for solving the contradiction.

The Inventive Principles are only generalized, analogous solutions. The problem solver must interpret these suggestions to find a solution that is appropriate to their specific application. For example, in our pointer problem, Inventive Principle 7, 'Nesting', might suggest a telescopic pointer. For more examples of specific ideas for these Inventive Principles please refer to Appendix 2.

Of course there are many other ways to formulate this contradiction besides length versus volume. Contradictions must be formulated to allow problem solvers to find the best solution. This, in itself, is a somewhat creative act, which may require several different attempts. For example, by formulating the conflict as one of Weight of a mobile object (attribute 1) versus Volume of a mobile object (attribute 7) Inventive Principles 29, 2, 40, and 28 would have been suggested as potential solutions. Inventive Principle 28, Replacement of a mechanical system

with a field: magnetic, electric, or electro-magnetic, might have led to the idea of inventing a laser pointer.

Using the Invention Matrix to solve the vacuum cleaner problem:

For the 'Y' axis of the matrix, consider one entity (the tool, air) whose attribute is to be improved. For example: Rate of air flow maps to attribute (1), Weight of mobile object. Refer to the highlighted row of the matrix. On the 'X' axis, four attributes that deteriorate when CONVENTIONAL means are used to carry away heavy particles have been identified by boxing the intersected cells in the matrix:

1. Suction force is reduced, i.e. Force, attribute (10)
2. We have to vacuum longer, i.e. Duration of action of mobile object, attribute (15)
3. The amount of removed debris may be reduced, i.e. Quantity of substance, attribute (26)
4. The vacuum cleaner's design becomes more expensive and complex due to costly add-ons, like electric power brushes, i.e. Device complexity, attribute (36).

Next, record the highlighted Inventive Principles at each 'X – Y' intersection. For the first intersection, row 1 and column 10, Inventive Principles 8, 10, 18, and 37 are suggested as potential solutions. The intersection of row 1 and column 15 adds Inventive Principles 5, 31, 34 and 35 as potential solutions. Repeat this exercise for other realistic attribute combinations. For example, the objective selected to operate on may be to increase the vacuum's suction, attribute (10), Force, which is the second highlighted row in the matrix. Alternatively, the objective may be to reduce the complexity/cost of expensive add-ons, attribute (36), Complexity, the third highlighted row. Record all of the Inventive Principles (highlighted) at the 'X-Y' intersections and consider using the most frequently occurring Inventive Principles to solve the vacuum cleaner problem. In this case, the most frequently occurring Inventive Principles, with each arising three times, were:

18. Vibrations: Consider adding pulsating 'spikes' to the air suction to increase the debris separation force and thus possibly eliminate the need for the electric power brush.
26. Copying: Rather than using one large vacuum 'head' with diminishing suction at its extremities, i.e. furthest from the vacuum tube outlet, consider using multiple, miniature vacuum 'heads'. Each multi-furcated flow opening is in close proximity with the carpet for maximum suction.
29. Pneumatics and hydraulics: Consider replacing the electric power brush with low flow but high pressure, pneumatic, focused air jets.

Or consider using combinations of the above Inventive Principles to solve the vacuum cleaner problem. For example, use pulsating, low flow but high pressure focused air jets (instead of rotating electric brushes) in combination with high suction flow.

TECHNIQUE 6: SOLVE WITH THE TRENDS OF SYSTEM EVOLUTION

During his research of the world-wide patent base, Altshuller also discovered that technological systems tended to evolve along certain prevailing 'vectors' (each with discrete phases), which he termed the Trends of System Evolution. Appendix 3 defines 34 Trends of System Evolution and provides examples for each. The following six major 'vector' groupings of the 34 trends listed in Appendix 3 define how most systems tend to evolve:

1. Transition to a higher level, or multi-object system
2. Non-uniform rate of sub-system evolution
3. Shortening of energy path
4. Increasing flexibility, from rigid mechanical to pliable to electrical
5. Transition from macro to micro-level
6. Increasing ideality

The evolution of the printing industry provides an example of all six trend vector groupings at work. At the start, the printing press had a single, rigid print plate. Transition to a higher level, multi-object system (1) occurred with the invention of the typewriter, which provided the flexibility of printing up different pages, one after another. However, typewriter cost reduction efforts eventually hit a major roadblock. Typewriter keys proved difficult to cost reduce and could not keep up with the rate of cost reduction improvements of other typewriter components, i.e. the non-uniform evolution of sub-systems (2). This system conflict was removed with IBM's Selectric typewriter ball, i.e. 'one typewriter key' with all the alpha-numeric on it. This in turn shortened the energy path (3) via removal of numerous mechanical typewriter linkages. Increasing flexibility (4) in turn was achieved in the Selectric typewriter through use of electro-magnetic instead of mechanical drive mechanisms. Transition from macro to micro-level (5) occurred with the transition of mechanical print mechanisms, typewriter keys, to ink jet and then laser printers. A higher level of ideality (6) was reached when the printer was totally eliminated, through use of the computer monitor (ideal machine).

However, not all trends, or even vector groups, may apply to any one system. Applicability is subject to the action or entity that needs to be satisfied. The user must scan through the trends to assess their applicability. For product or process improvement, use Trends 1 to 33. For measurement improvement use Trend 34. In addition, Trend 1, Ideality, serves as a high level explanation of what all trends ultimately try to achieve.

The Trends of System Evolution are very flexible in how they can be applied. Like the Invention Matrix, the Trends can be used to develop the means to improve system performance by solving contradictions. However, they can also be used in three other ways: to assess a product's innovation potential, for competitive analyses or benchmarking, and to help differentiate products already in the market.

6.1 Product Performance Improvement: To improve system performance by eliminating a contradiction, ask: Can the action or attribute be improved with *Trend 1, Ideality, or Trend 2, Space Segmentation,...* or all the way to the last Trend 34, Reduced Need for Measurement? The different trends are reviewed one by one for applicability to the situation to be improved until one is found with the potential to do so. Applicability of the Trends is illustrated using the pointer example again.

The pointer's desirable attribute is adaptability, the ability to point at things wherever they are. Scanning through the trends and their examples finds Trend 13, Increasing System Flexibility: rigid → jointed → multi-jointed → elastic → liquid/gas → field → 'nothing'. Hence, a one piece pointer would be in phase 1 of its evolution, and a multi-jointed (telescopic) pointer in phase 3 of this evolutionary progression.

The question of "Whether the *action* or *attribute* can be improved with/by *Trend 'X'*?" for eliminating contradictions for this example becomes: Can the pointer's *adaptability* be improved with/by progressing through *rigid → jointed → multi-jointed → elastic → liquid/gas → field → 'nothing'*? Yes of course, using a field, such as a laser pointer, the length of the pointer can be both very small and very long. Better yet, evolve to 'nothing,' the Ideal Machine. For example a computer monitor's curser produces a pointer that is very short and yet extremely long when viewed by many during a web cast presentation.

6.2 Product Innovation Potential Assessment: The second way in which the Trends of Evolution can be used is to assess a product's innovation potential. By repeating the process of defining applicable Trends to one entity at a time for a product, (its components, sub-systems, the system, super-system) a Trends of Evolution 'spider' diagram can be created. This diagram defines the current state of evolution for any one product entity and also the remaining 'headroom' for improvement (see Figure 12). Figure 12 might, for example, represent eight applicable Trends of Evolution for one entity, the bristles of a toothbrush. Trend Vector 1 might represent Surface Segmentation (Trend #3) with phase 1: being a flat surface of bristles, phase 2: a profiled surface more contoured to the tooth/gum profile, phase 3: a dimpled surface for more efficient cleaning, and phase 4: a porous, breathing surface where hollow bristles are filled perhaps with an aromatic and/or disinfecting fluid. Other trends might be Increasing Human Experience (#24b) for different colored bristles, or Mono-bi-poly functionality (#18), for bristles with different functions like massaging, abrasion, deep crevice cleaning or extraction, and so on.



Figure 12. Toothbrush Bristle: Innovation Potential Assessment, and Competitive Analysis

6.3 Product Competitive Analyses or Benchmarking: Competitive analyses also can be performed by repeating this process for a competitor's product and then overlaying the two spider diagrams. By comparing the firm's position on individual Trend Vectors with those of a competitor, the following can be determined: comparative relative evolutionary positions, Trend Vectors where the firm lags the competitor, where the firm leads the competitor, and where there is 'head room' to improve the products performance (See again, Figure 12). On some occasions, an evolutionary phase may have been skipped, and developing a product based on that phase might provide a more cost effective alternative, or a new niche application. Although not necessary, once again, commercial software² is available to facilitate analyses using The Trends of System Evolution.

6.4 Product Differentiation: The Evolutionary Trends provide a fourth application, product differentiation through the addition of brand new applications and features to the product. Once again, this technique can be applied to a system component, a sub-system of the system, the system itself, or the super-system, i.e. what the system itself, belongs to. For example, the typing keys on a computer's keyboard are defined as components. The keyboard is a sub-system of the computer. The computer is the system. And finally, the internet is the super-system the computer belongs to. To achieve a differentiated product simply scan through the Trends and for each phase of a Trend ask, "What new applications or features will: 'X' → 'Y' → 'Z' → ... provide? This becomes a disciplined yet very broad approach to achieving lateral thinking.

Different Trends in various combinations can be used to increase product differentiation. For example, for increasing a chair's differentiation, phase 4, 'scented' pores of Trend 3, Surface Segmentation, could be combined with phase 5, traveling wave (body massaging) of Trend 15, Coordination of Force Dynamics, and with phases for hearing and vision of Trend 24, Increasing Human Experience, to provide a virtual reality chair. These options can be thought of as many different combinations within a multi-dimensional space, or for simplicity and ease of visualization, a Product Differentiation Cube (Figure 14). The X and Y axes of the cube represent the 34 Trends of System Evolution for component 1 and component 2, respectively, and the Z axis represents the phases of each Trend. Thus we can combine different Trends and phases to obtain different feature and application combinations for different component, sub-system, and super-system combinations of a system. The Product Differentiating Cube, with multiple axes (more than X, Y, and Z), provides for exploring a multitude of component combinations using a disciplined methodology for uncovering an almost infinite number of potential, lateral thinking choices of new ideas, potentially not yet considered by customers.

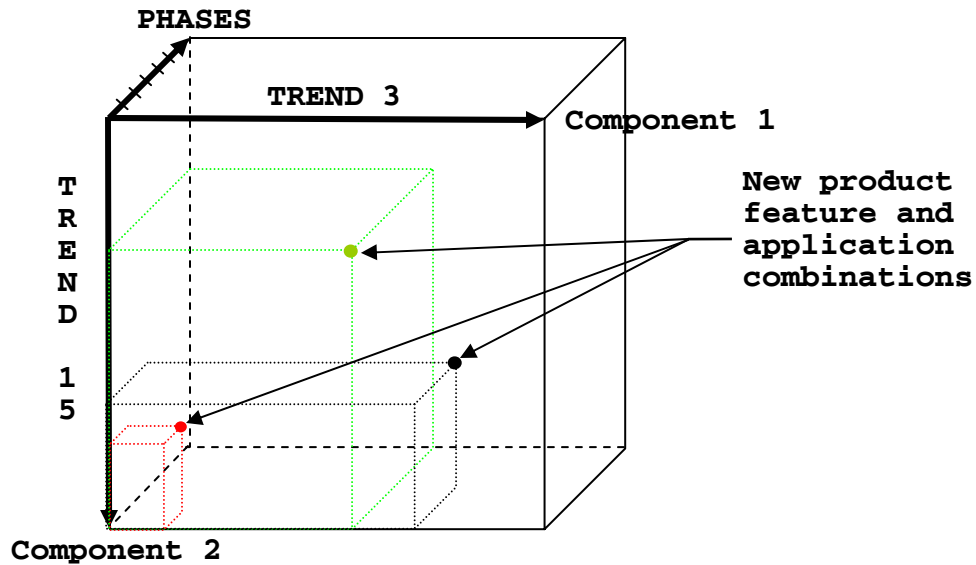

Figure 14. Virtual Reality Chair, Product Differentiation Cube

In summary, 34 Trends of System Evolution, each with discrete phases associated with how systems evolve over time provide the following capabilities:

1. Product performance improvement through elimination of its contradiction
2. Product innovation potential assessments
3. Product competitive analyses or benchmarking
4. Product differentiation with brand new:
 - Applications, and
 - Features

Use Trends of System Evolution to solve for the vacuum cleaner:

The function is force. Scanning through the Trends produces Trend 15, Coordination of Force Dynamics, as a potential pathway for considering improvements:

Continuous action → Pulsed action → Resonance → Several Actions → Traveling Wave

Trend 30, Evolution of Fields (Force), is another potential improvement pathway:

Mechanical → Thermal → Chemical → Electrical → Magnetic → Electromagnetic

The vacuum cleaner is in the first phase of evolution for each Trend, with plenty of 'head room' for improvement. The next step in the performance improvement process is to ask whether the force of the vacuum cleaner can be improved with/by Trends 15 or 30. For Trend 15, pulsed action suggests using ultrasonic air. Resonance suggests using air as an amplifier that tunes itself to the resonance frequency of the carpet fibers. Several actions suggest steady state high flow with an intermittently pulsed high pressure. For Trend 30, electromagnetics suggests the possibility of replacing or augmenting mechanically forced air, with electro-static force, perhaps obtained from the air flow's friction.

In using the Trends to increase a vacuum cleaner’s differentiation, just one subcomponent will be looked at briefly: air suction. Trend 19, the Anti-bi system suggests a potentially new application for the vacuum cleaner by using it as an anti-system to its current function, and turning into a mini-compressor – perhaps operating as a leaf blower, for example. Alternatively, applying phase three, “Resonance,” of Trend 15, “Coordination of Force Dynamics” could lead to the feature of deeper cleaning of carpet fibers, while pulsed on-off action (phase 2 of the same trend) could lead to the added feature or benefit of being able to clean blinds without pulling them of their rack.

Using several of the Trends, it is quite common to obtain numerous brand new, product differentiating applications and features for a single entity like a simple chair or vacuum cleaner. For additional new features and applications, the Product Differentiation Cube concept should be applied to other vacuum cleaner components, sub-systems, the vacuum cleaner itself, or the larger system it’s a part of, i.e. the vacuum cleaner/carpet/human super-system.

TECHNIQUE 7: SOLVE THE PROBLEM USING THE PHYSICAL EFFECTS DATABASE

Thousands of physical effects from science and examples from many industries have been captured in a software² knowledge base using written descriptions, animation, technical and patent references (see the endnotes for details). By using various ‘functional’ search words, the software provides numerous product differentiation examples that can be used to create brand new product applications and features. In addition, these databases are especially helpful when trying to improve a system’s performance or when it must be made to work again after costly and poor quality functions are pruned away. The effects database provides us with answers from industries or areas of expertise outside our knowledge base.

As an example, suppose that NASA was forced to reduce the weight of their space probes. During their ‘pruning’ process heavy batteries, a source for electricity, were removed. Is there some in-situ source of electricity in space? Typing into the computer various search words like temperature and electro-motive force (EMF), produces the Seebeck Effect as a potential solution (see Figure 15). This is an effect whereby voltage is generated across a metallic object that experiences a temperature differential such as a space probe. The probe’s side facing the sun experiences blistering heat, whereas the side facing interstellar space is at sub-zero temperature.

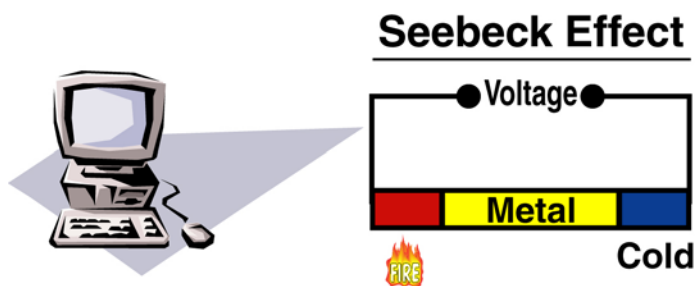

Figure 15. Seebeck Effect

Use the Physical Effects Database to solve for the vacuum cleaner:

Using search words like separate or move substance, the database repeatedly provides examples recommending high pressure, pulsating air jets.

SUMMARY AND CONCLUSIONS:

This chapter introduces seven inventive TRIZ techniques, first by defining them and using general conceptual examples and subsequently by applying them to a mature technological system, the vacuum cleaner. For each inventive technique our goal was to improve the vacuum cleaner's performance by eliminating the trade-off that deteriorated the system's primary function, suction. In addition, Inventive technique number 6, The Trends of System Evolution, was used to illustrate not only how it can be used for system performance improvement but also for:

1. Product renaissance via genesis of brand new product applications and features,
2. Innovation potential assessments that define a system's potential for performance improvement, and
3. Competitive analyses and benchmarking.

Using Technique 1, the Contradiction was defined as producing maximum suction and maximum flow concurrently, and the concept of high-low oscillating pressure pulses was obtained as a possible solution.

Technique 2, The Ideal Final Result and The Ideal Machine concepts, suggested use of electro-static force generated by the air's friction, to assist the vacuum cleaner's suction.

Technique 3, Pruning suggested:

- A fan that supplies both: suction (high flow), and high pressure (low flow)
- Air (assisted by pulsating high pressure air jets, >>> the 3 PSI of current vacuum cleaners)
- Cyclonic self-cleaning air (no filter required) e.g. the Dyson Cyclone vacuum cleaner.

Technique 4, Physical Separation, suggested separating with time the contradictory requirements of high suction and high flow by using pulsating high/low pressure suction.

Technique 5, The Invention Matrix, suggested Inventive Principles to improve performance:

- 18, Vibration, i.e. pulsating air
- 26, Copying, a multi-furcated nozzle for localized high pressure
- 29, Pneumatics, compressed air for high pressure, or
- combinations of the above.

Technique 6, The Trends of Evolution, suggested:

- Trend 15, Coordination of Force Dynamics: ultra-sonics, resonance and intermittent steady state flow with pulsed pressure spikes
- Trend 19, Anti-bi system: the combination suction and pressure
- Trend 30, Evolution of Fields (force): use of electro-static force

Technique 7, a Software database search recommended, once again, pulsed, high pressure air, and the use of centrifugal force to separate the debris from the air and thus eliminate the need for the filter (Dyson Cyclone vacuum cleaner).

From the above recommendations, three stand out as potentially world class solutions.

- First, the use of the vacuum cleaner's fan to provide both high flow and high pressure pulsed air flow. This solution should allow for removal of the expensive electric power brush.
- Second, the use of resonance as an amplifier to transform low suction into a high output force through increased carpet fiber oscillation. This phenomenon is the same as using a violin's amplification effect, resonance, to break a wine glass.
- Third, the elimination of clogging filters through the use of self-cleaning cyclonic air, i.e. the Dyson Cyclone vacuum cleaner.

And finally, the following list of additional surprise benefits, or super-effects, is a secondary outcome:

- Improved, deeper in-pile carpet cleaning through the use of carpet fiber resonance,
- Reduced weight and size resulting from the elimination of the electric power brush and air filter,
- Intermittent, on-off air pulsations facilitate cleaning of drapes without pulling them off their rack,
- The additional capability to use of the vacuum cleaner as a mini-compressor,
- Synergistic force amplification resulting from the combined force differentiation of suction with pressure, and finally
- The many fold increase of force over the 3 PSI provided by current vacuum cleaners.

KEYS TO SUCCESS IN APPLYING TRIZ TECHNIQUES:

The terminology used to describe the 'Invention Matrix, (Attributes, Inventive Principles) and The Trends of System Evolution is, at the start, a bit confusing, but with some practice, becomes very easy to use. Another point to keep in mind, don't become a prisoner of your words when formulating contradictions, the ideal final result, or function diagrams. Avoid the use of technical jargon, like centrifugal motion, and use simple, all encompassing phrases or verbs like rotate instead.

Preoccupation with software can be disappointing without a fundamental understanding of TRIZ. It's analogous to using spreadsheet software without a basic knowledge of mathematics. Acquiring a thorough understanding of Techniques 1 to 6 is recommended before using the TRIZ software packages. Software automates analyses, but most problems can be solved without it. Also, after selecting a physical effect for possible use from the software database, consult an expert regarding in-depth understanding of its use and any possible negative side effects.

In order for TRIZ techniques to become part of an organization's culture, it is of key importance that an enduring commitment is made to it, and that individuals who genuinely enjoy problem solving and teaching are selected to become their corporate TRIZ champions.

ENDNOTES:

- 1 Use the master detectives for finding the root cause of the problem.
 - Pareto Rule: 80% of the defects comes from 20% of the issues.
 - R. Kipling: Who, Where, When, What, Why, How?
 - E. Goldratt: Theory Of Constraints for Cause & Effects attribute analysis.
 - D. Shainin: Don't guess, instead, 'listen to the parts, they're smarter than the engineers'

- 2 TRIZ Software:
Invention Machine Corporation, Goldfire Innovator™ Software provides:
 - Inventive Principles and examples from industry for solving contradictions,
 - The Trends of System Evolution for optimizing and differentiating systems,
 - Physical effects database with examples from industry, and
 - Function diagram mapping software.Their website is: www.invention-machine.com

REFERENCES:

- Altshuller, G. S., *Creativity as an Exact Science: The Theory of the Solution of Inventive Problems*, Gordon and Breach Science Publishing, New York, 1984.
- Altshuller, G. S. and Vertkin, I. M., *How to Become a Genius. Life Strategy of a Creative Person*, Belarus, Minsk, 1994 (in Russian).
- Altshuller, G. S., *40 Principles: TRIZ Keys to Technical Innovation, TIC, Worchester, 1998.*
- Dettmer, H. W., *Goldratt's Theory of Constraints*, Quality Press, Milwaukee, 1998.
- Roza, V., Ed., *TRIZ in Progress, III*, Detroit, 1999.
- Sklobovsky, K. A. and Sharipov, R. H., *Theory, Practice and Applications of the Inventive Problems Decision*, Protva-Prin, Obninsk, 1995 (in Russian).
- Terninko, J., Zusman, A., Zlotin, B., *Systematic Innovation: An Introduction to TRIZ (Theory of Inventive Problem Solving)*, Saint Lucie Press, Boca Raton, 1998.
- Savransky, D., Semyon, *Engineering Of Creativity*, CRC Press LLC, Boca Raton, 2000

THE AUTHOR:

Gunter R. Ladewig is president of PRIMA Performance Ltd., www.primaperformance.com a consulting company that specializes in product, process, and operational renaissance using TRIZ, Six Sigma, and Lean manufacturing techniques. PRIMA's provides fast track customer teaching tools with 'One Look TRIZ', and tough quality solving techniques like 'KISS', Keeping It Statistically Simple. Gunter is an expert in operational efficiency improvement and world class product design. In 1992 he was winner of IBM's Innovation Invitational, and in addition, twice on IBM's winning team of the *Government of Canada Award for Business Excellence: The Gold Award for Productivity*, and the Gold Award for Quality.

	W O R E S E N I N I N G																																										
	1	2	3	4	5	6	7	8	9	10	11	12	13	14	15	16	17	18	19	20	21	22	23	24	25	26	27	28	29	30	31	32	33	34	35	36	37	38	39				
1 Weight of mobile object	1																																										
2 Weight of stationary object		1																																									
3 Length of mobile object			1																																								
4 Length of stationary object				1																																							
5 Area of mobile object					1																																						
6 Area of stationary object						1																																					
7 Volume of mobile object							1																																				
8 Volume of stationary object								1																																			
9 Speed									1																																		
10 Force										1																																	
11 Stress or pressure											1																																
12 Shape												1																															
13 Stability of the object's composition													1																														
14 Strength														1																													
15 Duration of action of mobile object															1																												
16 Duration of action of stationary object																1																											
17 Temperature																	1																										
18 Illumination intensity																		1																									
19 Use of energy by mobile object																			1																								
20 Use of energy by stationary object																				1																							
21 Power																					1																						
22 Loss of Energy																						1																					
23 Loss of substance																							1																				
24 Loss of Information																								1																			
25 Loss of Time																									1																		
26 Quantity of substance/matter																										1																	
27 Reliability																												1															
28 Measurement accuracy																													1														
29 Manufacturing precision																															1												
30 Object-affected harmful factors																																1											
31 Object-generated harmful factors																																	1										
32 Ease of manufacture																																		1									
33 Ease of operation																																			1								
34 Ease of repair																																				1							
35 Adaptability or versatility																																					1						
36 Diverse complexity																																						1					
37 Difficulty of detecting and measuring																																						1					
38 Extent of automation																																						1					
39 Productivity/Capacity																																							1				

Appendix 1
(Click here to see larger Excel version)

APPENDIX 2:

40 INVENTIVE PRINCIPLES

1. Segmentation

- a. Divide an object into independent parts: bicycle chain, braided wire
- b. Make an object modular: Lago set, telescopic pointer, computer components
- c. Increase the degree of fragmentation: escalator, roller conveyor

2. Extraction/Removal

- a. Extract (remove or separate) a disturbing part or property from an object: I-beam Vs solid beam, use a glass fiber to separate the hot laser source from where the light is needed
- b. Extract only the necessary part or property: Polaroid sun grasses, a strainer

3. Local Quality

- a. Transition from a homogeneous structure of an object to a heterogeneous structure: concrete, plywood, anisotropic materials
- b. Make each part of an object function in conditions most suitable for its operation: tool box with different size compartments, the nail apron
- c. Make each part of an object fulfill different useful functions: Swiss army knife, manicure set

4. Asymmetry

- a. Replace a symmetrical form with an asymmetrical form: asymmetrical shapes for foolproof assembly, contoured handles for better gripping
- b. If an object is already asymmetrical, increase its degree of asymmetry: increase the curvature of hockey stick's blade in order to increase its puck shooting velocity

5. Combining

- a. Combine in space identical or similar objects, assemble identical or similar parts to perform parallel operations: honey cone, transistors
- b. Combine in time homogeneous or contiguous operations: synchronize manufacturing operations, parallel manufacturing operations, fan with multiple vanes instead of a single vane

6. Universality, Multi-functionality

Have the object perform multiple functions, thereby eliminating the need for other object (s): laser for cutting, fusing, cleaning

7. Nesting

- a. Place the object inside another which, in turn is placed inside a third object: paper cups, Russian Matrioshka dolls
- b. Pass an object through a cavity of another object: telescopic pointer, mechanical pencil, retractable seat belt

8. Counterweight, Levitation

- a. Compensate for the object's weight by joining with another object that has a lifting force: float for fishing, life jacket, balloon
- b. Compensate for the weight of an object by interaction with an environment providing aerodynamic or hydrodynamic forces: sail, wings, tides for surfing

9. Prior Counteraction, Preliminary Anti-action

- a. If an action has useful and harmful effects, replace it with an action that controls the harmful effect: heat treat material by annealing it to minimize the harmful effects of stress
- b. Create actions in an object that will later oppose harmful actions: provide anti-tension in advance for concrete by pre-stressing the concrete, use masking tape to 'prevent' overspray

10. Preliminary Action

- a. Carry out all or part of the required action in advance: pre-tinned electronic components, self-adhesive Band-Aids
- b. Prearrange objects so they can be used without losing time: nail apron, tool box

11. Cushion in Advance, Compensate Before

Compensate for the relatively low reliability of an object with counter measures taken in advance: plating, provide redundancy, tolerances, and lifeboats

12. Equipotentiality

Change the working conditions so that an object need not be modified, raised, or lowered: pit for oil changes, flexible coupling, a conveyor at a height so that parts can slide unto it rather than having to be lifted.

13. Inversion, the Other Way Around

- a. Instead of an action dictated by the specifications of the problem, implement an opposite action: to remove a part from a shrink assembly cool the inner part instead of heating the outer part, heat shrink tubing
- b. Make a moving part of the object or the outside environment immovable and the non-moving part movable: escalator, treadmill
- c. Turn the object or process upside down: hour glass, cook from above rather than below using infra-red radiation

14. Spheroidality, Curvilinearity

- a. Replace linear parts or flat surfaces with curved ones; replace cubical shapes with spherical shapes: replace typewriter keys with one IBM print “ball”, use circular ‘end less’ subway tracks rather than straight end-to-end tracks
- b. Use rollers, balls spirals: ball bearings instead of a sliding mechanism, use a wheel-type pizza cutter instead of a knife
- c. Replace linear motion with rotational motion, utilize centrifugal force: use a router instead of plane to remove wood

15. Dynamicity, Optimization

- a. Make an object or its environment automatically adjust for optimal performance at each stage of operation: self-adjusting tinted glasses, a belt that changes continuously changes from straight to curved
- b. If an object is immobile, make it mobile or adaptive. Make it interchangeable: use a ball point pen instead of the fountain pen, interchangeable screw driver heads/bits
- c. Divide an object into elements which can change position relative to each other: chain, adjustable wrench

16. Partial or Excessive Action

If it is difficult to obtain 100% of a desired effect, use somewhat more or less to greatly simplify the problem: dip and then skim or spin off the excess, approach the target quickly, but slow down just before it’s reached

17. Transition into a New Dimension

- a. Transition one-dimensional movement, or placement, of objects into two-dimensional; two-dimensional to three-dimensional, etc.: robots with 6 degrees of freedom
- b. Use multi-level objects instead of single level: multi-layer printed circuit boards, stacks of paper
- c. Tilt the object or place it unto its side: laptop screen, adjustable mirror
- d. Use another side: Mobius strip, double sided tape, knife with two sharp edges (sword)
- e. Project optical lines unto neighboring areas, or unto the opposite side of an object: reflecting telescope

18. Mechanical Vibration/Oscillation

- a. Set an object into oscillation: hammer drill, mixing by using shaking
- b. If oscillation exists, increase its frequency, even as far as ultrasonic: vibration plus ultrasonic cleaning, ultrasonic and thermo-sonic bonding
- c. Use an object’s resonance frequency: destruction of kidney stones with ultrasonic resonance
- d. Use piezoelectric vibration instead of mechanical vibration: quartz crystal clocks
- e. Combine electromagnetic energy with ultrasonic vibration: use micro-waves to melt materials and ultrasonic vibration to mix the liquids

19. Periodic Action

- a. Replace a continuous action with a periodic or pulsed action: DC Vs AC, parts sampling
- b. If an action is already periodic, change its frequency: Micro-processor frequency (ever increasing frequency of Pentium chips), water sprinkler

20. Continuity of a Useful Action

- a. Carry out an action continuously (i.e. without pauses) so all parts operate at full capacity: the synchronized assembly line
- b. Remove idle and intermediate motions: rotary cutters for cutting in any direction, during thermo-cycling of computers, perform diagnostic testing

21. Rushing Through

Perform harmful or hazardous operations at very high speed: inoculation “gun” instead of syringe to reduce pain, pass through high temperature quickly to prevent melting

22. Convert Harm into Benefit, “Blessing in Disguise”

- a. Utilize harmful factors or environmental effects to obtain a positive effect: gas from manure, waste recycling
- b. Remove a harmful factor by combining it with another harmful factor: use explosives to put out oil well fires, use an acid to neutralize a base
- c. Amplify a harmful factor to such a degree that it is no longer harmful: fight fire with fire by eliminating the main fire’s fuel (wood/trees)

23. Feedback

- a. Introduce feedback: cursor on computer screen, inspection, Statistical Process Control (SPC)
- b. If feedback already exists, reverse it or change its magnitude: part inspection: sampling Vs 100% inspection, increase the frequency of feedback for critical situations or parameters

24. Mediator, Intermediary

- a. Use an intermediary object to transfer or carry out an action: chisel plus hammer instead of just using the hammer, primers for paint adhesion
- b. Temporarily connect an object to another one that is easy to remove: magnet to hold photo onto fridge, air in air mattress, dry ice for cooling ice cream

25. Self-Service, Self-Organization

- a. Make the object service itself and carry out supplementary and/or repair operations: use a cyclone and have air clean itself, boomerang returns on its own, knife holder that sharpens
- b. The object should service or repair itself: a tire with an internal fluid that plugs a puncture
- c. Make use of waste material and energy: use a flywheel to store excess rotational energy; during low demand periods for electricity, have the generators pump water into elevated reservoirs for later use to rotate the generator turbines

26. Copying

- a. Use a simple and inexpensive copy instead of an object which is complex, expensive, fragile or inconvenient to operate: mock-ups, CAD drawings
- b. Replace an object by its optical copy or image: digital computer image, computer animation/simulation, optical inspection, projection lithography
- c. If optical copies are already used, replace them with infrared or ultraviolet copies: use infrared detection for seeing enemy soldiers in the dark

27. Inexpensive, Short-Lived Object Instead of Expensive, Durable One

Replace an expensive object by a collection of inexpensive ones, forgoing certain properties like longevity, or cost: paper/plastic bags, plastic eye lenses, paper towels

28. Replacement of a Mechanical System

- a. Replace a mechanical system with an optical, acoustic, thermal, or olfactory system: use a laser pointer instead of a mechanical pointer, use optical or acoustic measurement instead of mechanical measurement
- b. Use an electrical, magnetic or electromagnetic field for interaction with the object: magnets to hold things, eddy currents
- c. Change from static to movable fields, from unstructured fields to structured ones: alternating current instead of direct current
- d. Use fields in conjunction with field-influenced materials (e.g. magnetic materials): solenoids, liquid crystal displays (LCD’s)

29. Pneumatics and Hydraulics

- a. Use gaseous or fluidic objects instead of solid objects. These parts can now use air or water for inflation, or use pneumatic or hydrostatic cushions: air bearings, shock absorbers, vacuum pick-and-place
- b. Use 'Archimedes force' to reduce the weight of an object: a bridge or dock with pontoons
- c. Use negative or atmospheric pressure: to reduce the size of down-filled pillows put them in a plastic bag and remove the air
- d. Use foam to provide both liquid and gaseous properties plus light weight: injection molding to obtain foamed plastics

30. Flexible Membranes or Thin Film

- a. Replace traditional constructions with those made from flexible membranes or thin film: beer can, plastic shrink-wrap
- b. Isolate an object from its environment using flexible membranes or thin film: paint, surfactants on ponds to minimize evaporation

31. Use of Porous Material

- a. Make an object porous or add porous elements: sintered metal, bricks, air or liquid filters, strainers
- b. If an object is already porous, use pores to induce a useful substance or function: capillaries for suction, heat pipes, carbon for filtering or odor removal

32. Changing Color or Optical Properties

- a. Change the color of an object or its surroundings: RGB color mixing, bug lights
- b. Change the transparency of an object or its environment: transparent tape, glasses with dynamic transparency adjustment, optical lens coatings, polarized glasses
- c. Use color additives to observe an object, or process, which is difficult to see: add pigment to water entering a septic system for leak detection
- d. If color additives are already used, employ luminescent tracers: use UV paint to enhance readability

33. Homogeneity

Make those objects which interact with a primary object out of the same material or a material that is close to the primary object's properties: tooth fillings, to prevent contamination try to use like materials

34. Rejection and Regeneration

- a. Make portions of an object that have fulfilled their functions disappear (be discarded, dissolved, or evaporated) or modified during the work process: digestible medicine capsules, biodegradable bottles
- b. Restore used up parts of an object during its operation: toilette reservoir, ice cube dispenser

35. Transformation of Properties

- a. Change an object's physical state (to solid, liquid, gas, plasma): use ice bergs to transport water, use dry ice to cool and then disappear, Popsicle instead of liquid
- b. Change the concentration, consistency, rheology: magnetorheological materials, thixotropic materials like ketchup, super-saturated solutions
- c. Change the degree of flexibility: change the air pressure in shock absorbers
- d. Change the temperature or volume: balloon

36. Phase Transformation

Exploit changes in properties that occur during phase transitions of a substance: use boiling water to maintain a constant temperature of 100 deg. C., freeze water and change it from liquid to solid, Curie point where materials change from magnetic to non-magnetic

37. Thermal Expansion/Contraction

- a. Use a material which expands or contracts with heat: Use heats shrink tubing to hold separate items, use thermal compression for assembly of parts,
- b. Use materials with different coefficients of expansion: bimetallic springs

38. Use Strong Oxidizers, Enriched Atmospheres, Accelerated Oxidation

- a. Replace normal air with enriched air: breathing apparatus,
- b. Replace enriched air with pure oxygen: oxy-acetylene torch
- c. Change oxygen to ionized oxygen:
- d. Use ionized oxygen:
- e. Replace ionized oxygen with ozone: to promote complete combustion

39. Inert Environment or Atmosphere

- a. Replace the normal environment with an inert one: Use Nitrogen during soldering to minimize oxidation of solder joints, hermetic enclosures
- b. Add neutral or inert additives to an object: To prevent oxidation shield an object with Argon
- c. Carry out the process in a vacuum: vapor deposition of metals

40. Composite Materials

Replace a homogeneous material with a composite (multiple) material: alloys, fertilizer, plastics with fillers, carbon fiber composites

APPENDIX 3: 34 TRENDS OF EVOLUTION

Trend 1, Ideality, serves as a high level model of what all the trends ultimately try to achieve. For technological process or product improvement use trends 2 to 33. For improving measurement systems use trend 34.

$$1. \text{ Ideality} = \frac{\uparrow \sum F \text{ Useful}}{\downarrow \sum F \text{ Harmful}} \quad \begin{array}{l} F = \text{function: } \cdot \text{Increase} \uparrow, \text{Decrease} \downarrow \\ \sum = \text{Sum of: Quantity, Magnitude, and Rate} \end{array}$$

This trend represents an integrated summation of all the trends that follow. Technological systems tend to evolve towards providing greater value, i.e. more useful functions and fewer harmful functions. Useful functions include the primary performance related functions of the system, support functions, functions for other applications, i.e. a laser pointer that's also a pen light or level, and desirable features of the system. Harmful functions include those that incur cost or deteriorate useful functions. The objective is to increase the quantity, magnitude and rate of improvement of, useful functions. For harmful functions, the objective is the exact opposite. One technological system that's probably closer to ideality than any other is the computer. Not only does it perform its basic function, computation, faster and faster, it performs many other functions like those of a phone, a book, a fax, etc. Furthermore, it has many desirable features like mobility and light weight. On the other hand, its harmful functions like cost, dollars per computation, and poor quality have dramatically improved from the early 80 foot by 30 foot, vacuum tube ENIAC computer.

2. Space Segmentation:

Monolith → single cavity → multiple cavities → pores → capillaries with active additives

Example - Cooling device: Solid block → single fin → multiple fins → porous Fins → capillary heat pipes

3. **Surface Segmentation:** Flat → wavy → dimpled → with active 'breathing' pores
Example – Paper: Flat → corrugated → bubble-wrap → scented wraps
4. **Segmentation (cutting):** With Solid (axe) → segmented (saw) → liquid → gas or plasma → field
Example - Cutting tool: Knife → grinding wheel → water jet → plasma arc → laser
5. **Trimming (pruning):** Multi-part system → Reduced part system → Single component system
Example - Automobile's display: many gauges, miniature LCD's → one LCD monitor
6. **Complication/Simplification (reducing):** Few functions per item → many functions per item
Example - Separate phone, fax, printer, calculator, copier → the computer
7. **Introduction of Voids:** Two objects → voids into one object → voids external to one object → voids around both objects → voids between objects
Example - Bearings: Bushing → sintered → roller bearing → → air bearing
8. **Increasing Asymmetry:** To provide additional function
Example - Mittens → gloves, left and right → gloves with grip surfaces
Mistake proof assembly designs, e.g. 'Poke-yoke'
9. **Flow Segmentation:** Single stream → bifurcated → several streams → many streams
Example - To provide more controllability, flows are segmented so that flows can be diffused, focused, opposed, differentiated, e.g. water nozzle: single stream → many → mist
10. **Geometric Evolution (Line):** Geometric structures evolve from a single point towards complex, three dimensional structures.
Point → line → 2D curve → 3D curves → 3D complex curve
Example - Hydraulic tubing: straight → u-shaped → 3D spiral → curved 3D spiral
11. **Geometric Evolution (Surface):** Flat → cylindrical → spherical → complex
Example - Sky lights, mirrors
12. **Geometric Evolution (Space):** Cubic → cylindrical → spherical → egg-shaped → spiral
Example - Vases, fuel tanks, loudspeakers
13. **Increasing System Flexibility:** rigid → jointed → multi-jointed → elastic → liquid/gas → field → 'nothing'
Example – Measurement: Ruler → folding ruler → tape measure → sonic detector → laser
14. **Coordination of Actions:** No matching → forced → buffered matching → self matching
Example – Production: Machines working at different rates → rate controlled by slowest process → use of buffer stock → autonomous self-control (own power source & sensory feedback)

15. **Coordination of Force Dynamics:** Steady state → pulsed action → resonance → several actions → traveling wave
 Example - Surface cleaning: continuous water jet → pulsed jet → jet tuned to surface's resonance frequency → e.g., combinations of pulsed and continuous → sweeping motion jet
16. **Macro to Micro Trends:** System based on: different components → same components → same small components → substance structure → molecular phenomena → atomic phenomena → fields
 Example - Bolts, rivets → thread, zipper → powder, aerosol → crystals, solder → glue → ionized materials, isotope → heat, light, magnetic or electromagnetic fields
17. **Poly-functionality: mono-bi-poly, with similar Objects:** Mono → bi → tri → poly systems
 Example - One lead pencil → multi-lead automatic pencils
 One transistor → multi-transistor integrated circuit
18. **Mono-bi-poly, with various Objects:** Mono → bi → tri → poly systems
 Example - Knife → Swiss army knife
 Screw driver → Multi-bit screw driver
19. **Anti-bi Systems:** Pencil with eraser, heater/cooler, Peltier transistor
20. **Mono-bi-poly Shifted Systems:** One color pencil → multi color automatic pencil
21. **Mono-bi Competing Systems:** Turbo-prop plane, balloon-propeller plane, and telescope with mirrors and lenses (Maksutov System)
22. **Mono-bi Compatible Systems:** Two part epoxy, symbiotic systems: Wasted heat used to heat another system, compensating systems: tinted glasses
23. **Increased Dynamicity:** To increase responsiveness: One tolerant state → several tolerant states → dynamically tolerant → artificially tolerant (via feedback) → intolerant
 Example: Foundation → switch → car → F15 Jet fighter → Nitroglycerin
24. **Increasing Human Experience:**
- a: Increase use of senses: Taste + smell + vision + touch + hearing
 - b: Color: Monochrome → binary → visible spectrum → full spectrum (Maxwell's spectrum)
 - c: Transparency: Opaque → partially transparent → transparent → with active elements (glasses that adjust for brightness)
 - d: Value: performance → reduced cost → reliability → features → other new uses
 - e: Product: Commodity → new product → service → experience → transformation
 Example: Bread → Ipod → concierge → river rafting → spiritual/religious transformation

25. Increasing Controllability: Uncontrolled system → manual → manual with power assist → self-controlled/feedback → smart self-control

Example - Exit opening → door → switch actuated door → door with motion detector → badge reader actuated (expert systems/artificial intelligence assisted)

26. Increasing Degrees of Freedom, DOF: 1 → 2 → 3 → 4 → 5 → 6 DOF

Example: 'X' direction → 'X' + 'Y' → 'X' + 'Y' + 'Z' → 'X' + 'Y' + 'Z' + 'X/R' rotation
→ 'X' + 'Y' + 'Z' + 'X/R' + 'Y/R' → 'X' + 'Y' + 'Z' + 'X/R' + 'Y/R' + 'Z/R', or any in-between combinations, example: the robot arm

27. Introduction of Substance: For 2 interacting objects, A & B: 1 – Introduce internal to A or B, 2 – External to A/B, 3 – To environment around A & B, and 4 – Between A & B

28. Introduction of Modified Substances: Introduce modified versions of A or B, in similar ways as outlined above in trend number 27

29. Introduction of Fields (Force): For 2 interacting objects, A & B: Same as for item 27

30. Evolution of Fields (Force): Mechanical → Thermal → Chemical → Electrical → Magnetic → Electromagnetic

Example: Mechanical: gravity, friction, centrifugal force, surface tension, vibration, sound,
Thermal: heating, cooling, evaporation, condensation, sublimation, radiators
Chemical: Explosions, combustion, polymerization, catalysts, taste, smell
Electrical: Electric current, electrostatics, electrolysis, piezoelectric
Magnetic: Magnetizing, demagnetizing, induction, magnetic solids/liquids
Electromagnetic: electro-statics, light (infrared to ultraviolet), radio waves

31. Reduced Human Involvement: Human → human + tool → human + semi-automated tool → human + fully automated tool → autonomous tool

Example: Human → human augur drill → human with electric drill → human with automatic drill press → robot

32. 'Clever' Materials: That overcome contradictory requirements:

Example: Materials with shape memory: straight when pulled, curled when wound
Hard and soft: Ice → water
Large and small: Heat-shrink tubing, piezo materials
Hot and cold: Peltier transistor
Magnetic and nonmagnetic: Curie point materials

33. Reduced Energy Conversion: (To increase efficiency) Many conversions → Zero?

Example: Propeller plane, Chemical → thermal → mechanical (rotation) → mechanical (pressure drop)

Hand glider: Gravity → pressure drop/velocity

34. **Reduced Need for Measurement:** Measure attributes → Detect (yes/no) → No direct measurement (self- regulating, or measure: a by-product or a model))

Example: Measure temperature in degrees → Detect if substance is > or < 'X'° → Self-regulate the temperature of a system at 100°C by using water which can't exceed its boiling temperature of 100°C

Using a By-product: Detect disease by analyzing a human being's: blood, temperature, etc.

Using a Model: Use a digital (model) picture of a human being's finger print or pupil to identify them.

Note: If a measurement system needs to be improved we can do it with Trends listed above. Trends 27, 28, and 29, introduction of substances or fields, are particularly useful.

APPENDIX 4: Ideal ways of eliminating a harmful action

- Eliminate the need for the Useful Function of the tool of a harmful action and, therefore, for the tool itself.
- Perform the Function of the Tool of a Harmful Action but eliminate the Tool itself.
- Destroy the tool of the Harmful Action:
 - If there is a tool, S2, of a harmful action make it disposable or remove or destroy it entirely (or portion-by-portion) after completion of its or a portion of its useful action.
- Eliminate the need for the Function of the Object of a Harmful Action
- Perform the Function of the Object of a Harmful Action but eliminate the Object itself.
- Destroy the object of the Harmful Action (see above)
- Eliminate the Consequences of a Harmful Action:
 - Eliminate the consequent Harmful Action the Object causes on the System
 - Correct the Deviated Product
 - Correct the System in which a Deviated Product functions
- Turn a Harmful Action into a Useful Action

APPENDIX 4: (cont'd)

Direct ways to transform () a harmful action:

Insulate S1 (object) from the harmful action by a substance insulator Sx:

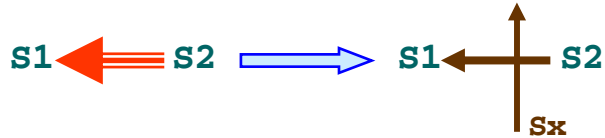

Protect S1 from the harmful action by a safety substance Sx which attracts the harmful action onto itself:

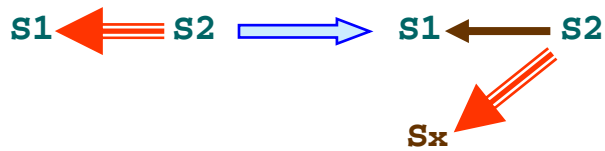

Modify the tool S2 of the harmful action to turn off the harmful action:



Modify S1 to be non-sensitive to the harmful action:



Counteract the harmful action with an opposing field Fx:

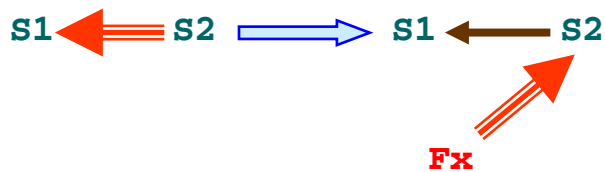

Alter the amount of the zone of the harmful action, its duration or both to decrease to decrease it or eliminate it totally.

Harmful Action 

APPENDIX 5: Inserting substances and fields

Substances and field:

- Injecting a Substance. Use
 - The Object or the Tool
 - Tool or Object related substances
 - Substance from sub-system(s), the system, Super-system, or environment
 - Products of above
 - Modified versions or combinations of above
 - Any substance

- Using a Force
 - Use similar logic as above
 - MeThChEM

APPENDIX 5: (cont'd)

Indirect ways of introducing a substance:

- Introduce 'emptiness' instead of substance
- Combine resource substances; use chemical reaction (s)
- Introduce a field instead of the substance
- Introduce the substance outside the object
- Use small but very effective quantity
- Concentrate or make substance structured
- Introduce temporarily or for a very short time
- Make substance disappear or turn into same substance as object
- Introduce substance and then modify it
- Modify object itself or its surroundings
- Destroy or decompose a resource substance to create the required substance
- Introduce a substance in a model of the object

APPENDIX 5: (cont'd)

Unique ways to introduce a field:

- Introduce a very strong field in a very small zone
- Create a sufficient field by concentrating, structuring, or accumulating an insufficient field
- Introduce a field temporarily, for a short period of time, or a very strong field for a very short period of time
- Alter a resource field
- Modify a resource substance

APPENDIX 6: Basic Fields

Basic Fields of Science:

- Mechanical
- Thermal
- Chemical
- Electric
- Magnetic
- Electromagnetic
- Nuclear
- Gravitational

APPENDIX 6: (cont'd)

Basic Mechanical Fields:

- Capillary pressure
- Deformation
- Pressure
- Pressure difference
- Pressure pulse
- Tension, Torsion, Compression
- Motion Forces: Gyro, kinetic, momentum, potential energy
- Gravity
- Friction: Kinetic, static
- Osmosis
- Diffusion
- Absorption/Adsorption
- Van der Waals
- Waves:
 - Acoustic
 - Gravitational
 - Impact
 - Mechanical
 - Standing
 - Ultrasound
 - Resonance

APPENDIX 6: (cont'd)

Basic Thermal Fields:

- Heat energy
- Heat flow
- Phase transitions
- Temperature
- Temperature gradient

Basic Chemical Fields:

- Chemical reactions:
 - Hydration
 - Ionization
 - Neutralization
 - Oxidation
 - Polymerization
 - Recombination
- Decomposition
- Substitution
- Biological:
 - Smell
 - Taste
 - Numerous others

APPENDIX 6: (cont'd)

Basic Electric Fields:

- Charge
- Current:
 - Alternating
 - Direct
 - Electric
 - Eddy
 - Pulse
- Discharge:
 - Arc
 - Avalanche
 - Corona
 - Electric
 - Glow
 - Spark
 - Streamer
- Electric:
 - Energy
 - Field
 - Impulse
- Electromotive force
- Polarization:
 - Dielectrics
 - Conductors

APPENDIX 6: (cont'd)

Basic Magnetic Fields:

- Static
- Alternating
- Non-uniform
- Pulse
- Diamagnetism, para-magnetism, ferromagnetism
- Ampere force
- Lorentz force
- Magneto-static spin waves

Basic Electro-magnetic Fields:

- Static
- Alternating
- Non-uniform
- Pulse
- Diamagnetism, para-magnetism, ferromagnetism
- Ampere force
- Lorentz force
- Magneto-static spin waves

APPENDIX 6: (cont'd)

Basic Nuclear Fields:

- Flow:
 - Alpha-particle
 - Electrons
 - Ions
 - Neutrons
 - Protons
 -
- Radiation
- Synthesis
- Fission
- Transformation
- Annihilation

Basic Gravitational Fields:

- Force
- Waves
- Moment